

Guideway mounted 0/4-20mA current source Signal generator Q01H09B(0/4)(X)(M) User Manual V1.30



1 Main technical indicators

- 1.1 DC DC24V power supply voltage range: DC15V-- DC28V
- 1.2 AC AC220V (optional) Power supply range: AC85-264V or DC110-370V
- 1.3 power dissipation < 2W
- 1.4 Output current range: 0mA --22mA (adjustable, factory set 0-20/4-20mA)
- 1.5 Output adjustment accuracy 0.1mA, error<0.05mA, load sampling resistance<500 ohms
- 1.6 **Working environment: 0-40°C , relative humidity <80%**

2 Dimensional drawing

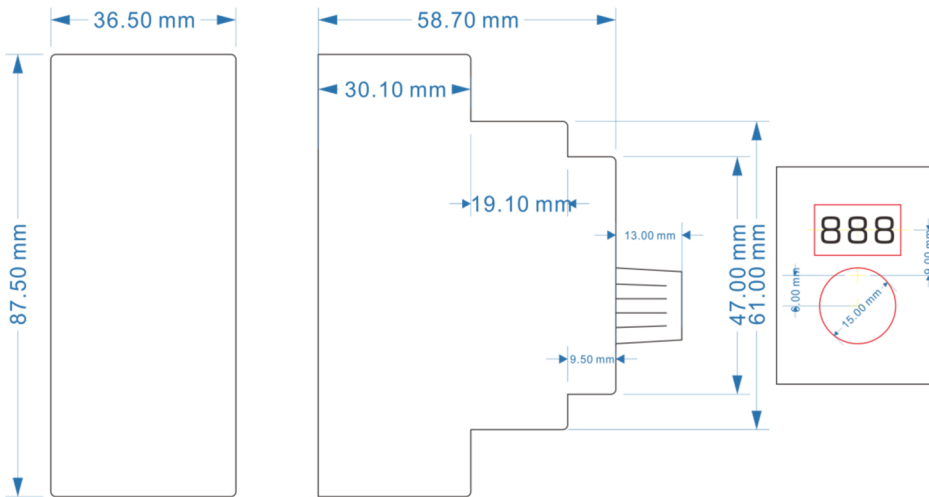

3 Wiring diagram

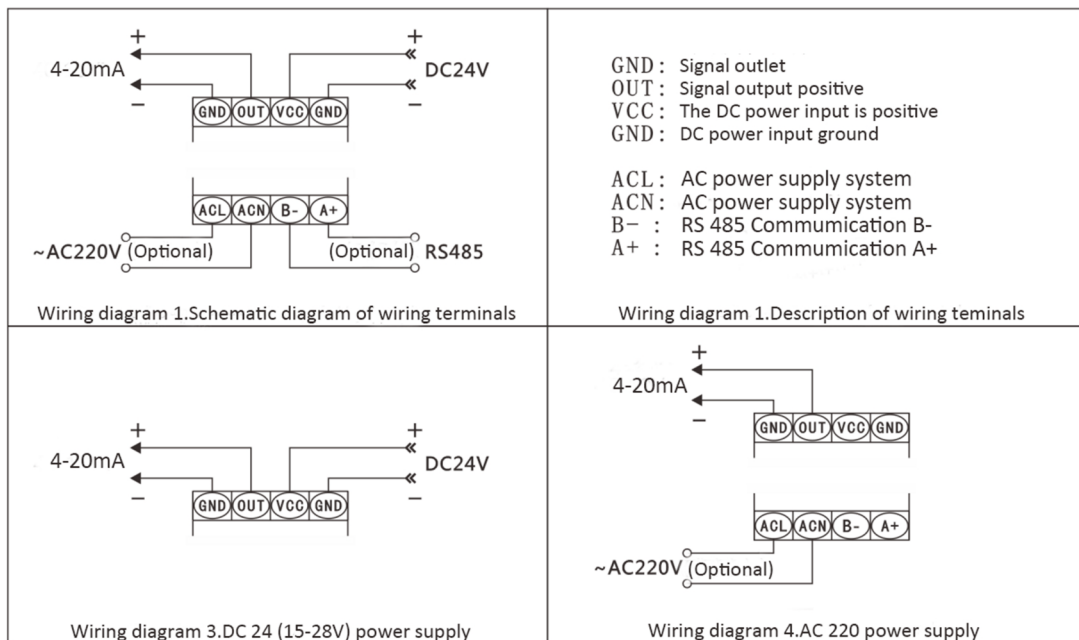

4 System operation (Turn clockwise for "+" and counterclockwise for "-", press the knob for "OK")

- 4.1 Saving default startup values: After adjusting the knob, press the knob to save, and start up as much as you want to save; Alternatively, set F04>0 and automatically save it 3 seconds after adjusting the knob;
- 4.2 Hold down the knob for 2 seconds to enter the parameter setting, and the parameter number "F01" will be displayed. When the parameter number is displayed, rotate the knob "+" and "-" to modify the parameter number, then press down the knob to modify the parameter value, and then press the knob to save and exit.
- 4.3 Parameter Description Table:

Number	Explain	Comment	Default
F01	Coarse or Fine tuning	0: coarse adjustment mode. F002 changes the addition or subtraction times	0

		1: Fine-tuning mode, "F003" to change the addition or subtraction	
F02	Coarse adjustment of addition and subtraction	1-50 (x 10)	1
F03	Fine-tune addition and subtraction	1-50	1
F04	Knob pressing function	0: Manually store the output value (fixed startup value); 1: Quickly switch between coarse and fine tuning; 2: Output OFF/ON; 3: Quick zeroing (minimum value); (Function 1-3: Automatically store as startup value 3 seconds after adjusting the knob)	1
F05	Output Range (mA)	0:0-20mA 1:4-20mA 2:0-22mA 3:0-24mA -1: custom	0
F06	Custom output low-end	0-24.0mA	0
F07	Custom output high-end	0-24.0mA	20.0
F08	Display mode	0: Actual current 1: Percentage 0-100 2:0-50hz 3:0-90 4:0-130 5:0-150 6:0-250 7:0-400 8:0-600 -1: custom	0
F09	Custom display low-end	-199 to 999 decimal points do not need to be ignored, set in F11	0
F10	Custom display high-end	-199 to 999 decimal points do not need to be ignored, set in F11	200
F11	Custom decimal point position	0-3 0/1:无 2:99.9 3:9.99	2
F12	Communication slave address	1-127	1
F13	Communication baud rate	0:2400 1:4800 2:9600 3:19200 4:38400 5:57600	2
F14	Communication check bit	0:8-N-1 1:8-N-2 2:8-Odd-1 3:8-Even-1	0
F15	Digital tube brightness	0(dark)---7(bright)	1
F16	4mA calibration value	-999 -- +999 Internal Reference, please be careful	
F17	12mA calibration value	-999 -- +999 Internal Reference, please be careful	
F18	20mA calibration value	-999 -- +999 Internal Reference, please be careful	

4.4 Example of setting and calculating the number of knob turns:

Press the knob for 2 seconds to enter the settings and display F01. Press it again to set its value to 0 (coarse adjustment) or 1 (fine adjustment), which can quickly switch the adjustment speed. The

multiple of coarse adjustment and fine adjustment can be set in F02 and F03;

Example for calculating the number of turns: Encoder knob rotates 20 grids per turn

Example settings	F01	F02	F03	explain
0-20mA display 0-20.0, knob adjustment 1 turn	0	x	1	Set fine tuning, with a change of 1mA per grid
0-20mA display 0-20.0, knob adjustment 5 turns	1	x	2	Set fine-tuning 2, one grid change of 0.2mA
4-20mA display 0-100, knob adjustment 1 turn	1	x	5	Set fine adjustment 5, with a change of 0.5mA in one grid

4.5 Default value saving method for startup, pressing the knob for other function settings:

F04=0: After adjusting the knob, short press the knob to save, and start up as much as you want to save;

F04=1: Short press the knob to switch to manual speed adjustment, which is equivalent to setting F001=0 or 1;

F04=2: Short press the knob, switch output, OFF state output is 0mA;

F04=3: Short press the knob to adjust the screen display value directly to the minimum value;

4.6 Example of Setting Output Range and Display Scale: (x indicates no need to set, and setting it does not affect)

Example settings	F05	F06	F07	F08	F09	F10	F11
0-20mA display 0-20.0 (current value)	0	x	x	0	x	x	x
0-20mA display 0-100 (% percentage)	0	x	x	1	x	x	x
4-20mA display 0-100 (% percentage)	1	x	x	1	x	x	x
4-20mA display 0-50 (HZ)	1	x	x	2	x	x	x
4-20mA display 0-90 (° angle)	1	x	x	3	x	x	x
4-20mA display 0-500 (speed)	1	x	x	-1	0	500	0
4-20mA display 0-1.60 (MPa pressure)	1	x	x	-1	0	160	3
4-20mA display -40 to 80 (°C temperature)	1	x	x	-1	-40	80	0
3-21mA display 3-21.0	-1	3.0	21.0	0	x	x	x
0.5-21.5mA display -20 to 200	-1	0.5	10.5	-1	-20	200	0

Note: Due to the inability to display 1000 with 3 digital tubes, A00 is used instead of displaying it

5 RS485 MODBUS Communication (Optional)

5.1 Adopt the standard MODBUS-RTU message format ,slave mode address 1-127(factory setting 1);

5.2 Baud rate 2400-57600(factory setting 9600)

5.3 The factory setting of the check bit is 8-N-1;

5.4 There is no 120Ω terminal resistance inside. When the bus speed transmission distance is long and there are many devices, the user needs to connect the terminal

resistance to make the transmission more stable. The use of high-quality twisted pair with shielding can increase the anti-interference ability of communication.

MODBUS-RTU Packet Format, Commands and Examples:

485 Slave address	1byte
Function code	1byte 03 or 06 order
Data	N byte
CRC Checkout	2byte Standard CRC16 Starter 0xFFFF

03 Query Multiple Registers Command, Example: Query 3 Registers Starting from Address 0

Send	01 03 00 00 00 03 05 CB
Return	01 03 06 00 00 00 00 00 21 75

06 Set a single register command, for example: set the value of register 1 to 100 (0x0064), and directly return the command

Send	01 06 00 01 00 64 D9 E1
Return	01 06 00 01 00 64 D9 E1

5.5 Register Table

Register address	Explain	Read write	Remark
0	Not have		PLC The data address starts at 1,so no
1	Current output digital display value	r/w	No decimal point
2	Spare	r/w	

6 Model suffix description:

Q01H09B(0/4)(X)(M)

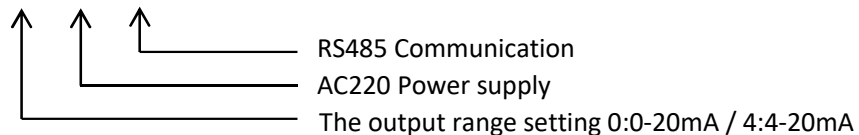

Give an example:

Q01H09B5 (Factory setting 4-20mA/Power supply DC24V/Without communication)

Q01H09B10XM (Factory setting 0-20mA/Power supply DC24V or AC220V/RS485 communication)

7 Precautions:

- 7.1 Please read this manual carefully before connecting cables
- 7.2 Please turn off the power before wiring, do not operate with live, pay attention to safety, beware of electric shock
- 7.3 Exceeding the demonstration range of technical indicators may cause abnormal operation or even damage to the instrument